

SINCE
2080

ADDAMS STONE MILL

General

Brand **ADDAMS**
Designation Stone Milling
Model SM Series with Models of 400/ 500 / 600/ 800 / 1200
Use Industry

Application Processing of Cereal grains and other seeds. Meeting your needs for high-quality, healthy whole meal flour, grits or high-class flour.

Other Applications like Lentil Splitting, Yellow Pea Splitting and Fava Bean Splitting are available with a change of stones.



HEALTHY FLOUR THROUGH OPTIMUM GRINDING:

The GRINDMASTER stone mill professionally and simply does the Job through the optimum milling process using proven and well-known **ADDAMS** millstones in a sturdy design. The heavy-duty mill, aimed for industrial purposes, has a strong frame, hardwearing shaft, and bearings. The adjustment of the stones has an adjustment gear for fine-tuning. All in all, an industrial mill is used for grinding whole grain into grits or healthy and good whole meal flour or for grinding of flour grits into high-class flour as the last break after a roller mill.

FINENESS COMPARED TO CAPACITY

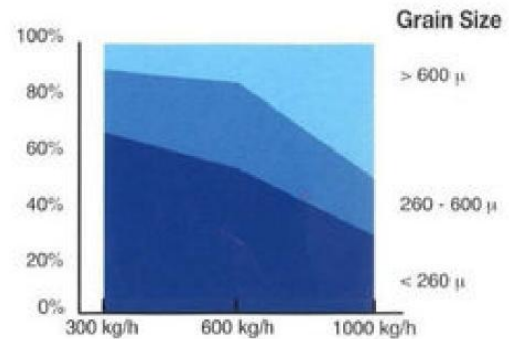

INDUSTRIAL OR DECENTRALIZED STONE GRINDING MILLS:

The superior thing about the GRINDMASTER stone mill, when used in **ADDAMS's** decentralized flour mills for milling high-class flour at a high yield, is that the process only uses 4 milling breaks. In this unique combination of 3 break roller milling and 1 break stone milling the stone mill produces high-quality, fine flour from the fine, white grits from the roller mill.

Shipment:

If you are looking for a single machine, we provide the Cargo parameters for each machine, so the buyer can calculate Transport cost to the delivery address and we will be more than happy to assist you in this matter please feel free to consult your sales agent.

Installation:

We supply technical documents and easy-install videos to our clients for safe handling. As well as our motto is 'Plug and Play' which makes our buyer's experience much easier with Impact Huller.

After Sales Support:

We have 7/24 online and on-call After Sales Support Department. For After-sales parts purchasing you can go to our online **addamsgroup.com** or download **our application** to order your required spare part.

SINCE
2080

SINCE 2080

ENVIRONMENTAL CONDITIONS

Environment Indoors
Temperature from -10°C to +40°C
Altitude Up to 1 000 m

NOISE Sound pressure level, empty 79.2 dB(A)

MODELS	CAPACITY	MOTOR	ELECTRICAL RATINGS	DIMENSIONS L x W x H	WEIGHT Empty
SM-500	100g kg/hr	7,5 kW	400 Volt 50 Hertz 3 Phase	800x600x100	250kg
SM-800	200 kg/hr	15 kW	400 Volt 50 Hertz 3 Phase	1300x1060x1670	550 kg
SM-1200	400 kg/hr	30-22kW	400 Volt 50 Hertz 3 Phase	1500x1560x1770	950kg

Note: Capacities may vary for different size seed inputs and micron-size outputs.

SM-800

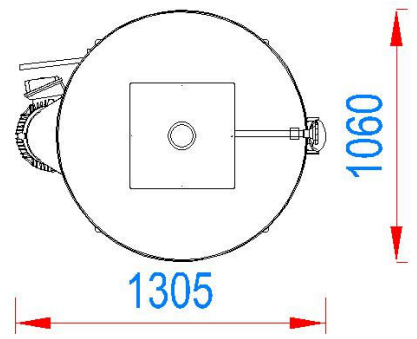
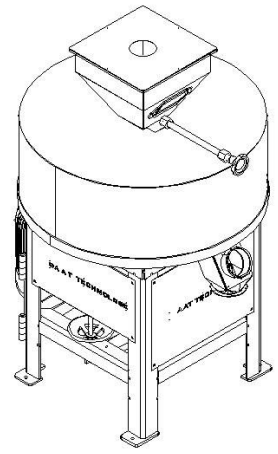
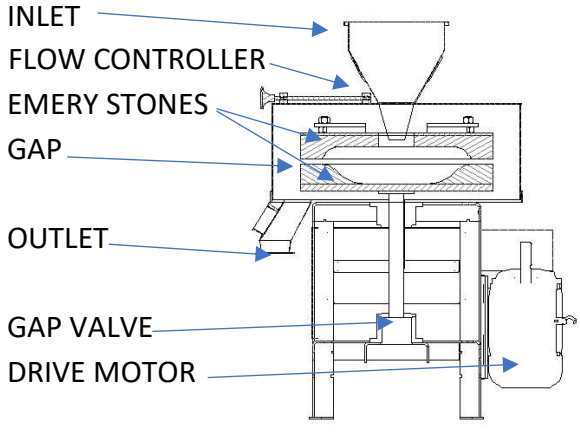
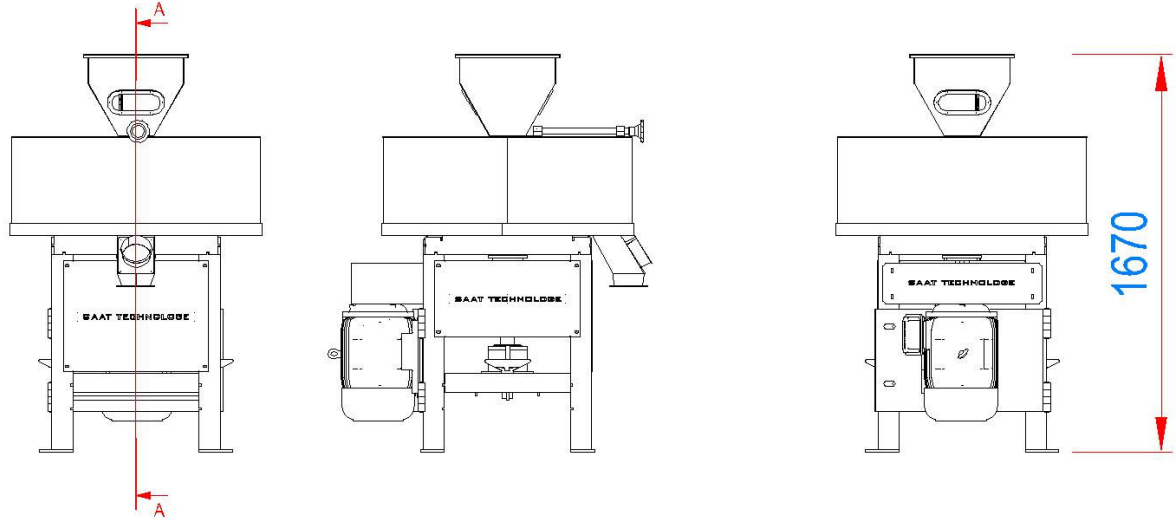

SINCE 2080