

SINCE  
2080

## ADDAMS PISTACHIO SHELLER

### General

Brand	ADDAMS
Designation	Pistachio Sheller
Model	AS 220
Use	Food Processing Industry
Application	Processing of Cereal grains and other seeds.

The Pistachio Sheller is a precise and efficient shelling unit suitable for pistachios in shell.



### Conditions before Shelling:

Pistachio to be shelled, should have been cleaned from outer dry pulp & separated from admixtures\*  
For optimal hulling yield, your sales representative will explain the required conditions in detail.

**Shelling Operation with Pistachio Sheller:** Nuts are fed into the hopper, and from the hopper, 2 Vibratory Linear feeders with VFD feed Pistachio to the Sheller Cylinder. Shelling Drum forces the Pistachios to pass through the grates where shelling occurs. For the best yield, Sizing of Pistachio nuts is required due to the Shelling Grates being fixed sizes. Multilabel Shellers are used for higher-capacity operations.

An industrial-duty machine with a long lifetime, ensured by a rugged design, features an easily replaceable Impeller and hulling ring fabricated from highly durable steel for enhanced wear resistance.

### After the Shelling Operation:

Pistachio Sheller breaks the shell of the Pistachio Nut and the output of the machine **Pistachio Shell**, **Pistachio Kernels**, and **Pistachio In shell** (none sheller) exist together. To obtain **Pistachio Kernels** there is a sequence to do the separation of **Pistachio Shell**, **Pistachio Kernels**, and **Pistachio In shell**. Your Sales representative will be happy to explain to you what machines are used to obtain the expected Kernel output.

### Food Grade:

Easy access to all parts of the machine.  
The food-grade painted surface is sufficient for Pistachio Seed processing equipment. Stainless Steel surface is optional.  
Food Grade Lubricants for bearings.

### Shelling yield:

Shelling yield ranges from 80 to 95 %, this high variation happens due to the right conditions being provided or not and we are happy to share our experience. Please consult your sales agent.

### Shipment:

If you are looking for a single machine, we provide the Cargo parameters for each machine, so the buyer can calculate the Transport cost to the delivery address and we will be more than happy to assist you in this matter please feel free to consult your sales agent.

SINCE  
2080

## Installation:

We supply technical documents and easy-install videos to our clients for safe handling.

As well as our motto is 'Plug and Play' which makes our buyer's experience much easier with Pistachio Sheller.

## After Sales Support:

We have a 7/24 online and on-call After Sales Support Department.

For after-sales parts purchasing, you can go to our online [adamsgroup.com](http://adamsgroup.com) or download our App to order your required spare part. If we have not opened an account for you, please go ahead and open your account, purchase your part, and it will get delivered to your address.

Note: Capacities may vary for different impurities, moisture contents, and seed variety.

## ENVIRONMENTAL CONDITIONS

Environment	Indoors
Temperature from	-10°C to +40°C
Altitude	Up to 1,000 m

### NOISE

Sound pressure level, empty 79.2 dB(A)

### Available Options

- An effective shell separation can be achieved with a Shell Blower Fan located at the outlet of the Pistachio Sheller.

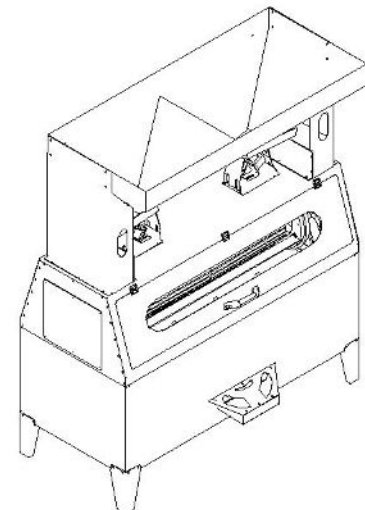
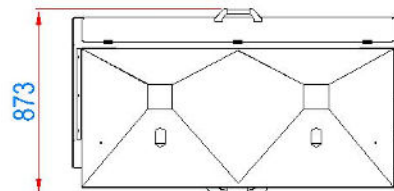
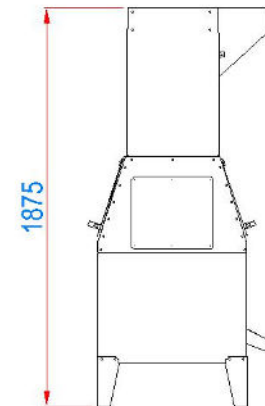
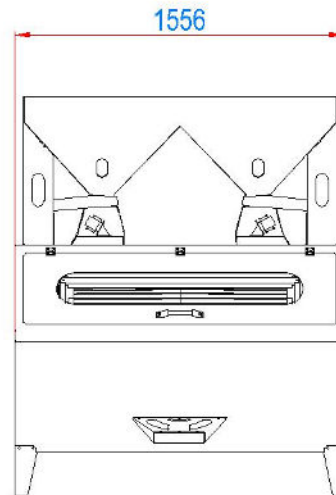

MODEL	PS-220
Width	873
Length	1556
Height	1875
Weight	500
Motor	0,75 kW
Capacity Pistachio	100kg/hr