

SINCE
2080

Science of Seed Processing



OPTIMIUM PRE-CLEANERS 240 SERIES

OPTIMIUM SEED PRE-CLEANERS 240 SERIES FLAT SCREEN TYPE

SINCE
2080

SINCE
2080

ADDAMS develops and manufactures solutions for pre-cleaning of all cereals, maize, rape seed, peas and similar seeds for before drying, storage or Processing. Pre-cleaning differs from rough cleaning in that this process is also able to separate admixtures, smaller, larger, and lighter than the main seed.

The ADDAMS product range encompasses ADDAMS OPTIMUM Pre-Cleaners, which are available in various types, including Flat Screen, Rotary Drum, Oscillating, and Vibratory Screen Cleaners.

ADDAMS Flat Screen OPTIMUM Seed Pre-Cleaners are a versatile screen cleaner specifically designed for pre-cleaning, utilizing a 5-15m² area in conjunction with a sophisticated aspiration system.

Pre-cleaning may replace rough cleaning when receiving a raw material from which, in addition to the large impurities, most of the sand, thin grain, and weeds are to be separated. Pre-cleaners have capacities ranging from 5 to 100t/h. All these cleaners have effective pre-suction and after-suction systems for the separation of light products such as chaff, straw, light grain, etc

OPTIMUM PRE-CLEANERS DISTINGUISHING FEATURES

1. FULL-WIDTH SHAKER FEEDER

- Has infinitely variable adjustment of the feed capacity via a separate control panel.
- Ensures uniform flow over the entire width of the screen.
- Considerably improves air cleaning. Since the product reaches the pre-suction area uniformly.
- Is Self-cleaning
- Is Gentle to Leguminous Seeds, Paddy Rice, Etc.
- Ensures Optimum Capacity Utilisation of the machine
- Ensures no downtime due to blocked Inlets
- Requires no cleaning when changing products

2. FEED ROLLER

- Has an adjustable capacity shutter in combination with infinitely variable speed control of the feed roller, which controls the feed capacity.
- Is not affected by lightweight waste material and large impurities such as stones, etc.
- Has a built-in spring-loaded safety device that protects the feed roller against damage.

3. PRE-SUCTION & POST-SUCTION SYSTEM

- Built as two separate air suction units.
- Can be connected to existing central aspiration systems. Due to the small air volume.

4. SCREW AUGER OUTLET for LIGHT REJECT

- Ensures Continuous Discharge of dust and waste from the air system via screw conveyors
- Has finger flaps to ensure optimal dust separation in the expansion chamber by preventing false air from entering the chamber

5. SCREEN BOXES PLYWOOD SWEDOTEX FILM

- Are moisture-resistant and Insect-resistant. And approved by the food industry
- Are constructed with replaceable wear plates and screen runners in exposed areas
- Have a long lifetime since the plywood easily copes with the vibrations of the screen box
- Give less resonance owing to the use of plywood, thus resulting in a better working environment.

6. DISTRIBUTOR

- Ensures 50% Distribution of the grain flow via the top and bottom screen boxes, respectively
- 50% and 33% of distributors ensure the distribution of the grain flow in each screen box between various screen rows.

7. ACCESS to the SCREENS

- The access hatches have snap-action locks
- The hatches are small and hinged at the bottom
- Rapid changing of screens

SINCE
2080

OPTIMIUM PRE-CLEANERS 240 SERIES

SINCE

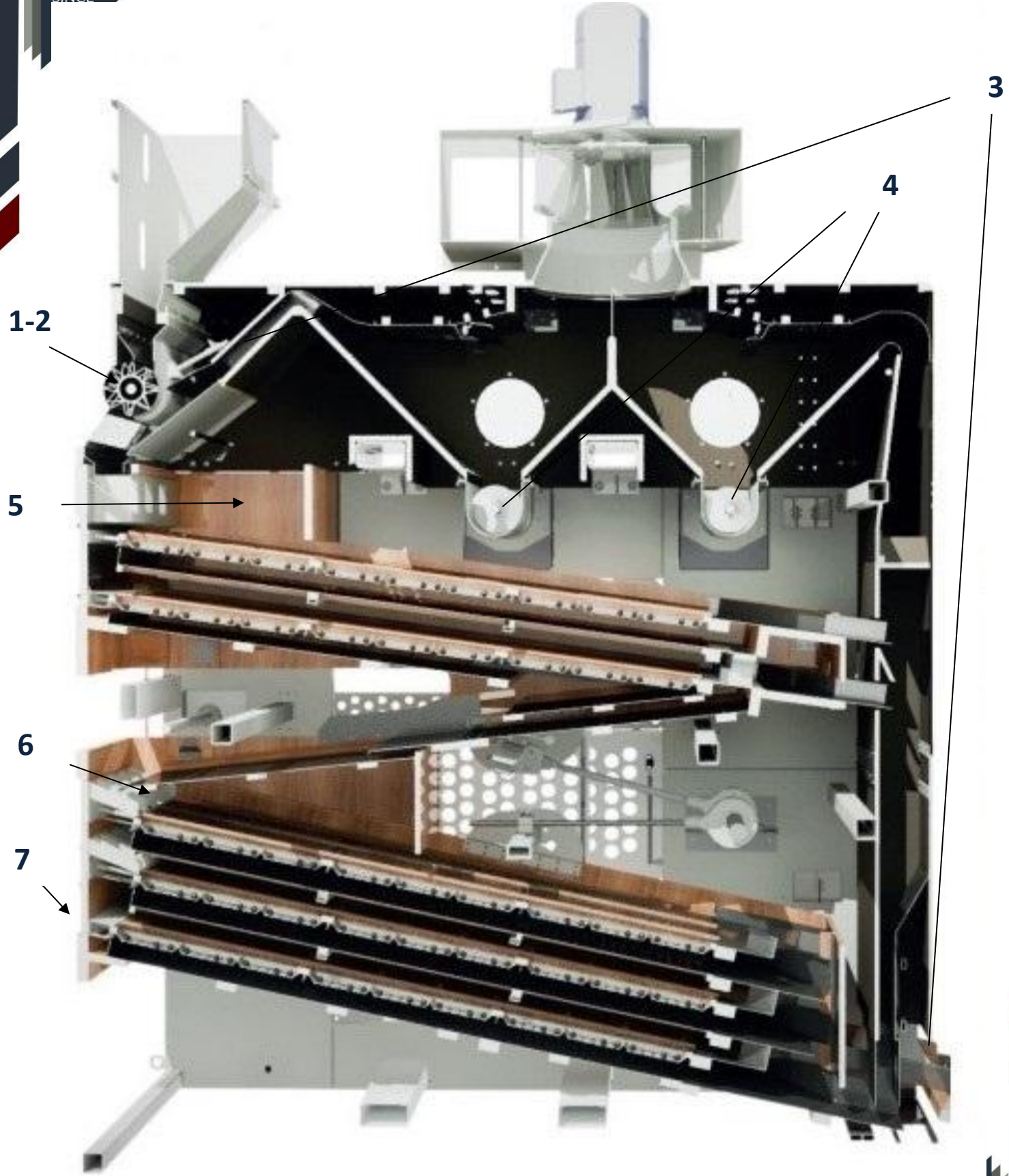

SINCE
2080

SINCE
 2080

8. CHANGE OF SCREEN INCLINATION

- Allows Different Capacity and Cleaning Results.
- Ensures Excellent Purity and Minimum Waste
- It is Easily Carried Out by Changing the Screen Hangers.
- The Machine can be used as A Pre-cleaner, Industrial Cleaner Or Fine Cleaner

9. OPTIMUM SCREENS FOR ALL PURPOSES

- Are Available with Round and Oblong Holes From 0.3 To 25.0 Mm
- Are Also Available as Wire-mesh Screens for Special Products
- Have As Standard Holes in The Screen Plates with Very Small Tolerances, Thus Ensuring Minimum Cleaning Loss
- Are Available in A Standard Size Of 1000 Mm (L) X 1800 Mm (W) = 1.8 M², Which Can Be Used in All OPTIMUM Cleaners, Thus Reducing the Number of Screens Required

10. BALL BOX

- Ensures Efficient Cleaning of Screens using Rubber Balls Which Are Food-Grade Approved
- Can Maintain the Cleaning Effect at Extremely Low Temperatures

As The Rubber Balls Are Moulded in A Material Particularly Well-suited to The Task

- Is Cast in One Piece to Prevent Trapped Seeds, Etc. (Self-cleaning)
- Is Separately Mounted in The Screen Box, Which Enables A Quick Change of Screens Without Removing the Ball Boxes

11. BALANCED ECCENTRIC SYSTEM

- Is Fitted with Counterweights That Ensure Smooth Running
- Results In Minimum Stress on Buildings And Steel Structures
- Is Fitted With » heavy-duty « Bearings
- Ensures Maximum Utilisation of The Cleaning Effect of The Screens Owing to Care- Fully Matched Stroke and Speed Of Rotation

12. SUSPENSION OF SCREEN BOXES

- The Screen Boxes Are Suspended in Rosta Suspension Units With Moveable Parts in Rubber
- Prevents Transmission of Vibrations to Buildings and Other Machines
- Ensures that the Machine Can Be Located Almost Anywhere- Where do we need to Be Established
- Balancing Of the Dynamic Forces in The Machine Ensures Extended Operation Without Repair

13. INCLOSED CLEANERS

- The Cleaners Are Closed
- The Doors Are an Integral Part of The Waste Pipe System
- Easy And Rapid Access to Replace Outlet Trays When Changing Flow

14. MOTORS

- Are Mounted Externally, Thus Resulting In Rapid And Simple Adjustment and Replacement Of The V-belts

15. COVERING OF SCREEN SECTIONS

- Both Screen Sections Are Covered with Galvanised Plate With Rubber Inspection Hatches
- There Is Dust Extraction from Each Screen Box

16. WEAR PLATES

- Replaceable Pehd 1000 And Hardox Wear Plates Are Located At All Exposed Surfaces
- Easy To Replace
- Repair Intervals Are Extended
- Repair Costs Are Reduced
- Are Moisture-resistant And Insect- Resistant, And Approved By the Food Industry
- Are Constructed with Replaceable Wear Plates And Screen Runners in Exposed Areas
- Have A Long Lifetime because the Plywood Easily Copes with The Vibrations of The Screen Box
- Give Less Resonance Owing to The Use of Plywood, Thus Resulting In a Better Working Environment

17. SAMPLING

- Handy Sampler
- Easy To Take Samples from The Various Outlet Trays

18. RECIRCULATING POST-SUCTION UNIT

- Ensures The Highest Purity of The Product using The Extraction of Lightweight Particles Such as Empty Kernels, Husks and Dust, Etc. When The Product Exits The Cleaner Via the Exhaust Unit

19. EXHAUST UNIT FOR CLEAN PRODUCT

- Distributes The Recirculated Air So That All Clean products Is Aerated
- The Remaining Lightweight Kernels and Dust Particles Are Separated
- Fresh Air is Supplied at The Same Rate as The Air That is Removed in the Mini-cyclone

 SINCE
 2080

SINCE 2080

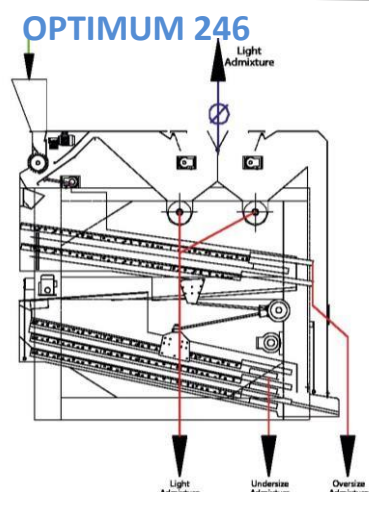
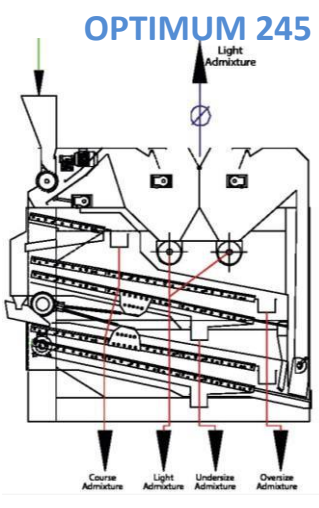
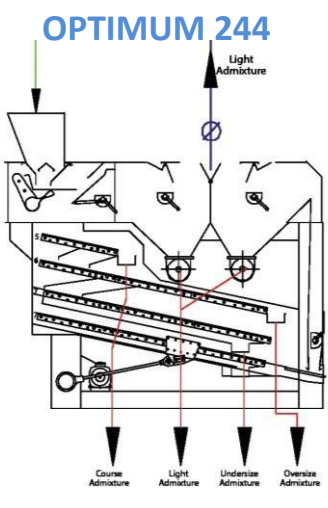
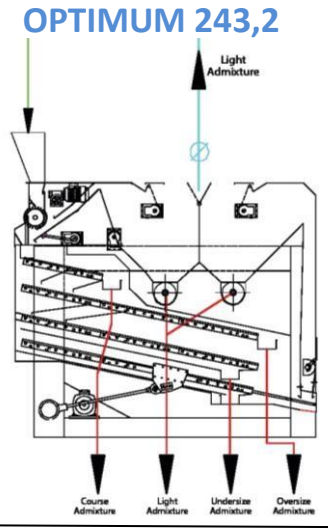
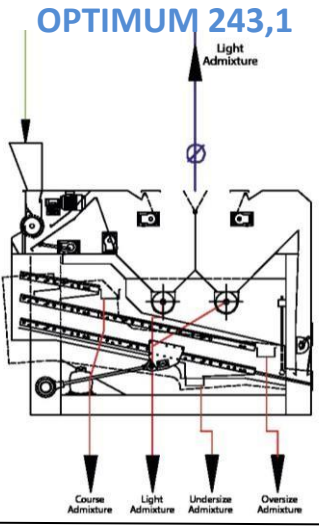
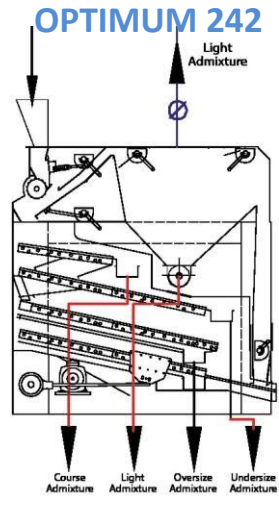

Technical Data & Capacity Chart					
UNIVERSAL Pre-Cleaner	242	243.1&243.2	244.1&244.2	245	246
Capacity Guide (max. 20% moisture)					
Pre-Cleaning	tph	tph	tph	tph	tph
Wheat and Barley	30	45	50	60	100
Rape Seed	25	35	40	50	90
Maize	25	35	40	50	90
Peas	25	35	40	50	90
Paddy Rice	12.5	17.5	20-25	30-35	45-50
Sunflower (14% moisture content)	12.5	17.5	20-26	30-36	45-51
Fine Cleaning (max. 15 % moisture content:					
Malting Barley	3-5 t/h	5-8 t/h	6-10 t/h	10-15 t/h	15-25 t/h
Seed Crain	1-3 t/h	3-5 t/h	4-6 t/h	6-8 t/h	8-12 t/h
Rape Seed (98% purity)	1-3 t/h	3-6 t/h	4-6 t/h	6-8 t/h	8-12 t/h
Maize and Peas	1-3 t/h	3-4 t/h	4-6 t/h	6-8 t/h	20 t/h
Total screen area:	5 m ²	7 m ²	10 m ²	13 m ²	15 m ²
Overall dimensions:					
Height (without fan)	2245 mm	2245 mm	2565 mm	2895 mm	3230 mm
Length	2235 mm	3012 mm	3012 mm	3270 mm	3625 mm
Width (incl. motor)	1940 mm	1913 mm	1913 mm	2300 mm	1958 mm
Motors					
Screens	1.5 kW	2.2 kW	2.2 kW	1.5 kW	1.1 kW
Fan	5.5 kW	5.5 kW	7.50 kW	7.50 kW	11.00 kW
Feeding roller	0.75 kW	0.75 kW	0.75 kW	1.1 kW	2.2 kW
Air Volume					
Pre and after suction	6400 m ³	10600 m ³	10600 m ³	11000 m ³	15000 m ³
Weight	1610 kg	1935 kg	2140 kg	2310 kg	3035 kg
Freight volume 11 m ³	11 m ³	15 m ³	17 m ³	22 m ³	25 m ³

SINCE 2080