

SINCE 2080

ADDAMS JOG CONVEYORS

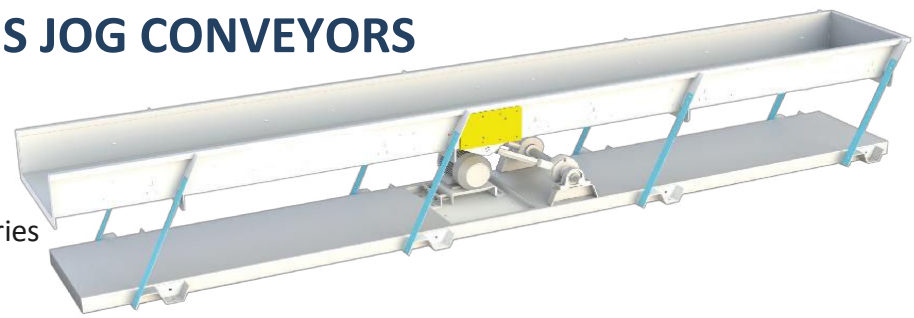

Brand **ADDAMS**
Model Vibratory Jog Conveyors- JC Series
Capacity range 14–42 m³/h
Shaft Speed 270–390 rpm

Application Conveying of Grains and seeds.
ADDAMS type JC vibratory conveyors are designed for gentle handling of dry bulk materials. Along with the ability to empty completely, this makes these conveyors ideal for use in seed plants where it is essential to keep the seeds pure and intact. Material can be loaded into the trough at any point along its length. Unloading is possible through outlet gates placed in the bottom of the trough, in addition to the discharge end. The conveyors are intended for horizontal conveying over shorter distances. For longer distances, several conveyors can be placed in succession. extraction and dosing.

FEATURES

- Open or enclosed sheet metal trough.
- Simple construction for minimal maintenance.
- Easy-to-replace wearing parts.

DRIVE SYSTEM

Multiple-V-belt drive for eccentric shaft.

ACCESSORIES

- Latched or bolted top covers.
- Manual or pneumatic gates, on request.
- Inlet spouts on the top.
- Outlet spouts under the gates & at the discharge end.

Characteristics	JC-12	JC-9	JC-7	JC-5
Maximum length	12 m	9 m	7 m	5 m
Maximum capacity	14 m ³ /h	22 m ³ /h	32 m ³ /h	42 m ³ /h
Drive motor size	1.1 kW	1.1 kW	1.1 kW	1.1 kW
	1500 rpm	1500 rpm	1500 rpm	1500 rpm
Small pulley diameter	ø56 mm	ø63 mm	ø71 mm	ø80 mm
Eccentric shaft speed	270 rpm	300 rpm	340 rpm	390 rpm
Sound pressure level	74 dB(A)	74 dB(A)	74 dB(A)	74 dB(A)
Dynamic load, horizontal	5 709 N	5 419 N	5 353 N	4 855 N
Dynamic load, vertical	1 854 N	1 760 N	1 738 N	1 576 N
Frequency	4.5 Hz	5 Hz	5.7 Hz	6.4 Hz

NOTE: The capacities and maximum lengths are only applicable if the foundation is sufficiently stable. If not, a decrease in capacity must be expected.

Environmental conditions

Ambient temperature	-20°C to +40°C as standard -5°C to +40°C with pneumatic gate
Installation location	Indoor Not for use in potentially explosive atmospheres
Eccentric shaft speed	Up to 1 000 m above sea level (motor)

Materials and surface treatment

Base	Steel
Trough	Steel or Stainless steel
Leaf springs	Glass reinforced plastic
Outside surfaces	Painted
Inside surfaces	Painted or unpainted

