

SINCE
2080

Science of Seed Processing

ADDAMS GRAIN CLIPPER



General

Brand	ADDAMS
Designation	GRAIN CLIPPER
Model	GC185
Use	Food Processing Industry
Application	Processing of Cereal grains and other seeds.

Horizontal, cylindrical surface cleaning machine (clipping of pubescence).

Conditions before Clipping:

Grain Clippers are used largely for Oat Hulling, Pearl Barley Processing, and Maize De-germination Processing. The seed to be clipped must be clean from all admixtures for effective results.

Clipping Operation with Grain Clipper:

The feeding product contains a mixture of unshelled and shelled oat kernels and loose husks. A screw conveyor is feeding the product into the working chamber. The degree of losing the pubescence is controlled by the counter pressure plate at the exit outlet. This plate is adjustable which influences the degree of cleaning. Special steel for feeding screws and ridged cylinder guarantees a long lifetime. Solidly built screens assure a long lifetime. A special working chamber ensures a high degree of reduction of pubescence. The special air system applies cool air in precise amounts, which helps to cool the machine and remove fine pubescence. An industrial duty machine with, a long lifetime ensured by a rugged design ensures an easily replaceable Impeller and hulling ring fabricated from a highly durable steel for wear resistance.

After Clipping Operation:

Grain Clipper creates a compression effect during processing and seed surface pubescence is removed, connected air aspiration to Grain Clipper **aspirates the fine particles**. For further separation of broken or chipped seeds, a Screen Separator can be used.

Food Grade:

Easy access to all parts of the machine.
The food-grade painted surface is sufficient for Almond Seed processing equipment. Stainless Steel surface is optional.
Food Grade Lubricants for bearings.

Clipping yield:

Shelling yield ranges from 80 to 95 %, this high variation happens due to the right conditions being provided or not and we are happy to share our experience. Please consult your sales agent.

Shipment:

If you are looking for a single machine, we provide the Cargo parameters for each machine, so the buyer can calculate Transport cost to the delivery address and we will be more than happy to assist you in this matter please feel free to consult your sales agent.

SINCE
2080

SINCE
2080

Installation:

We supply technical documents and easy-install videos to our clients for safe handling. As well as our motto is 'Plug and Play' which makes our buyer's experience much easier with Grain Clipper.

After Sales Support:

We have 7/24 online and on-call After Sales Support Department.

For After sales parts purchasing you can go to our online addamsgroup.com or download our **App** to order your required spare part, if we have not opened an account for you, please go ahead and open your account, purchase your part and it will get it delivered to your address.

Note: Capacities may vary for different impurities, moisture contents, and seed verity.

ENVIRONMENTAL CONDITIONS

Environment Indoors
Temperature from -10°C to +40°C
Altitude Up to 1,000 m

NOISE

Sound pressure level, empty 79.2 dB(A)

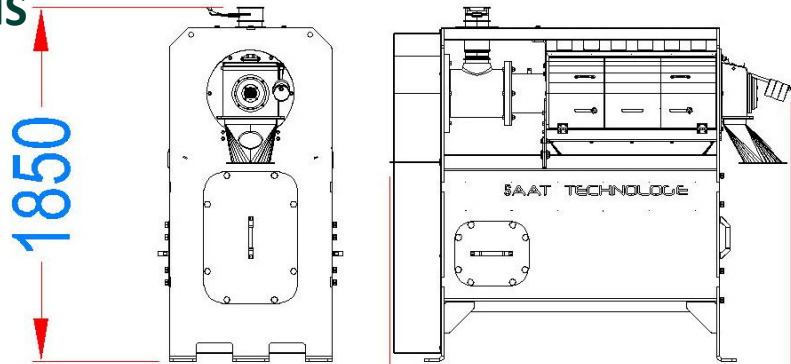

2100

MODEL	GC-185	GC-186
CAPACITY tph	up to 2.0	2.0-5.0
MOTOR kW	up to 11	up to 22
ASPIRATION m3 /min. daPa	20 - 100	30 - 100
NOISE LEVEL	75-85 dB(A)	75-85 dB(A)
Net Weight KG	400	700

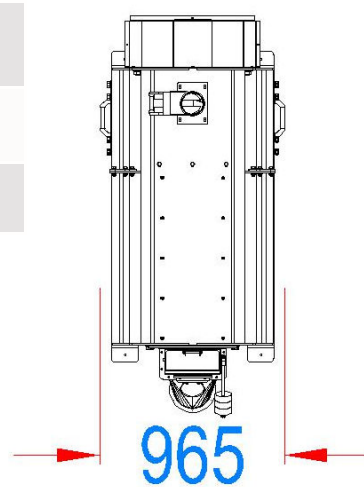

SINCE
2080