

SINCE
2080

Science of Seed Processing

Brand: **ADDAMS**
 Designation: De-awner
 Model: DA-183 & DA-184 Series
 Use: Seed Industry
 Application: Conditioning of cereal grains and other seeds.

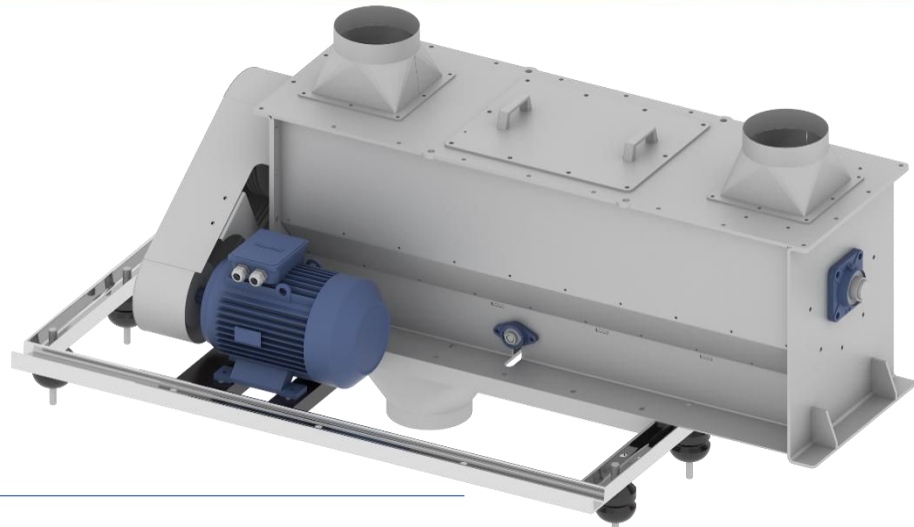

ADDAMS De-awners types DA-183 and DA-184 are specifically designed for the treatment of malting barley, seed grain, and all other seed varieties. The De-awners are employed mainly for the de-awning of barley, breaking up clusters of beet seed, and surface polishing of grains and vegetable seeds to improve the appearance and increase the bushel weight. The inclusion of a De-awner, with its cluster-breaking action, will greatly improve the performance of subsequent machines in the cleaning system. The de-awning process is usually carried out before cleaning, depending on the quality and type of grain or seed and the required quality of the finished material.

FEATURES

- Totally enclosed rigid steel casing.
- Shaft with round or square bars revolving at high speed.
- Manual slide gate for controlling the degree of treatment.
- Internal wear plate on the bottom and the sides.

CONTROLLERS

- Maintenance door with position switch with guard locking.

DRIVE SYSTEM

- Multiple-V-belt drive with electrical drive motor.

ACCESSORIES

- Extra inlet for material not to be treated (bypass).
- Support frame for floor or for Saat Technologie OPTIMUM cleaner.
- Outlet spout for Q-pipe system

POWER and CAPACITY CHART

DA-183 Series	DA-183.1	DA-183.2	DA-183.3	DA-183.4	
MOTOR	4 kW	5.5 kW	7.5kW	11 kW	
PRE-CLEANING	10 t/h	15 t/h	25 t/h	35 t/h	
FINE-CLEANING	2.5 t/h	4.0 t/h	6.0 t/h	9.0 t/h	
DA-184 Series	DA-184.1	DA-184.2	DA-184.3	DA-184.4	DA-184.5
MOTOR	7.5 kW	11 kW	15kW	18.5 kW	22 kW
PRE-CLEANING	30 t/h	40 t/h	50 t/h	60 t/h	65 t/h
FINE-CLEANING	5.0 t/h	12.0 t/h	15 t/h	18 t/h	22 t/h

Key: Values in parenthesis are for de-bearding. Other values are for general conditioning. Note: Capacities may vary for different impurity and moisture contents.

SINCE
2080

DIMENSIONS	DA-183 Series	DA-184 Series
Beater arm diameter	ø240 mm (28 beaters)	ø361 mm (36 beaters)
Overall length	1315mm	1610 mm
Overall height	702 mm	1085 mm
Overall width	1060 mm	1100 mm
Note: Dimensions include the stand-alone support frame		
WEIGHT		
Weight, empty	350 kg	555 kg
Weight, operating (wheat)	415 kg	740 kg
Weight, choked (wheat)	420 kg	755kg
Note: weights include the stand-alone support frame. Support frames for Optimum cleaners may add additional weight.		
OPERATING SPEED		
Beater arm shaft	740 rpm	
ELECTRICAL RATINGS		
Motor	4.0 kW; 5.5 kW; 7.5 kW or 11kw	7.5 kW; 11 kW; 15 kW; 18.5 kW; or 22 kW
NOISE		
Sound pressure level, empty	79.9 dB(A)	
COMPLIANCE		
EU machinery legislation	Yes	
EU ATEX legislation	No	
EU food contact legislation	Option*	
* Consult your Saat Technologe dealer for full details		
ENVIRONMENTAL CONDITIONS		
Environment	Indoors	
Temperature	From -10°C to +40°C	
Altitude	Up to 1 000 m	
SURFACE PROTECTION		
Casing	Paint (corrosivity category C2; low durability)	
LIFETIME		
Intended life limit	20 years	