

Science of Seed Processing

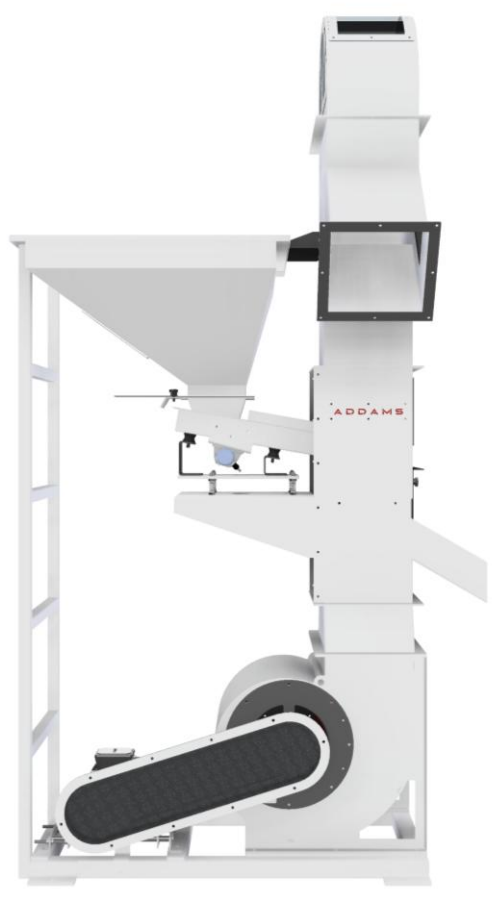

SHELL BLOWER SEPARATOR

SINCE
2080

'ADDAMS Shell Blower' separates Shells of nuts continuously from product flow, whether it be Pistachio, Walnut, Almond, Hazelnuts, Chestnut, etc.

- Excellent Separation Degree
- High Specific Capacity
- Reliable
- A simple and very effective way of Shell Separation.
- User-friendly.
- Easy Operation and Maintenance
- Customized solutions – adapted optimally to customer needs.
- To meet Project Capacity needs, a special design model of the 'Shell Remover Air Blower' can be adopted to address the requirement.
- Larger and Wider Models can be efficiently designed and manufactured.

Application Areas

- Almond Shelling Lines
- Walnut Shelling Lines
- Pistachio Shelling Plants
- Hazelnut Shelling Plants
- Chestnut Shelling Plants

SB-150 Model

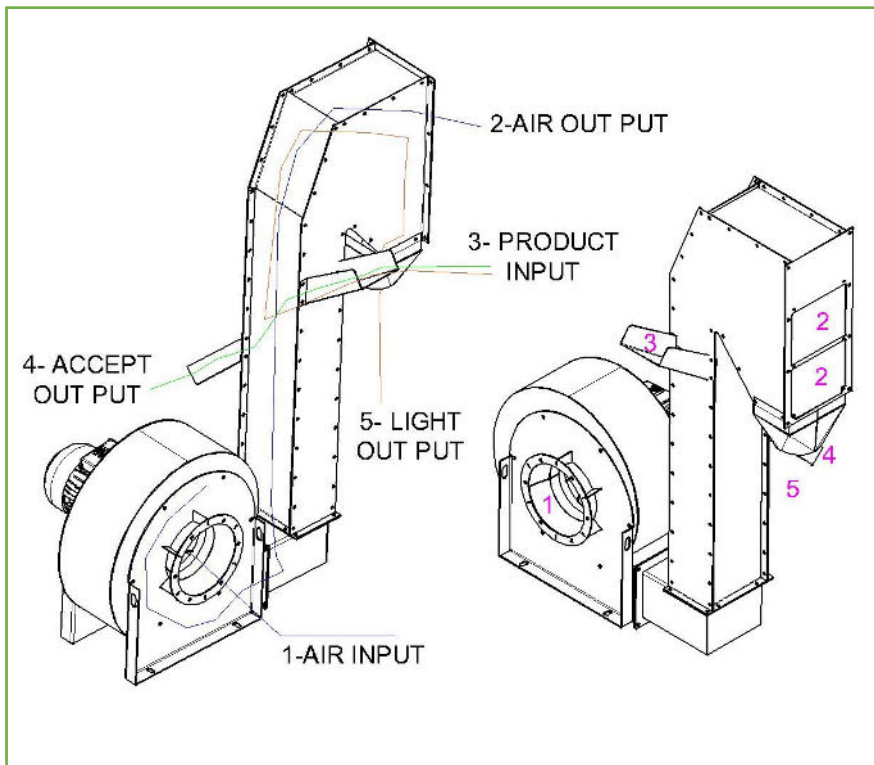

MODELS	SB-150	SB-300
Width	525	1300
Length	1060	1490
Height	1390	2600
Weight	60	420
Motor	0,55kW	4kW
Capacity	100kg/hr	500 kg/hr

SINCE
2080