

SINCE  
2080

# ADDAMS SEED TREATER

## Continuous Type

Brand: ADDAMS  
 Designation: Continuous Seed Treater Series  
 Model: CST Series  
 Application: Treating liquid or slurry application to the Seed.

### Application

The continuous treater is built for continuous treating of seeds. For this purpose, a treating liquid or slurry is applied to the seed. The machine has been designed in self-supporting all steel construction. All metal parts in direct contact with the treating agents are made of stainless steel.

### Process flow

**1. Intake hopper with feeder** The grain passes the rotary feeder which is equipped with an air classifier. The intake capacity can be adjusted by changing the speed of the rotary feeder.

**2. Spray chamber** (primary treatment) The product is distributed via a dispersal cone. The treating liquid passes through a hose pump into the spray chamber and is spread over the spinning disc on the product. The volume of the treating liquid can be adjusted by the rotation speed of the hose pump. The spinning disc is driven by a belt drive.

**3. Mixing chamber** (secondary treatment) The paddle screw mixing the product and carries to the outlet.

**4. Control unit** The control of the system could be done either by PLC or by relay control.

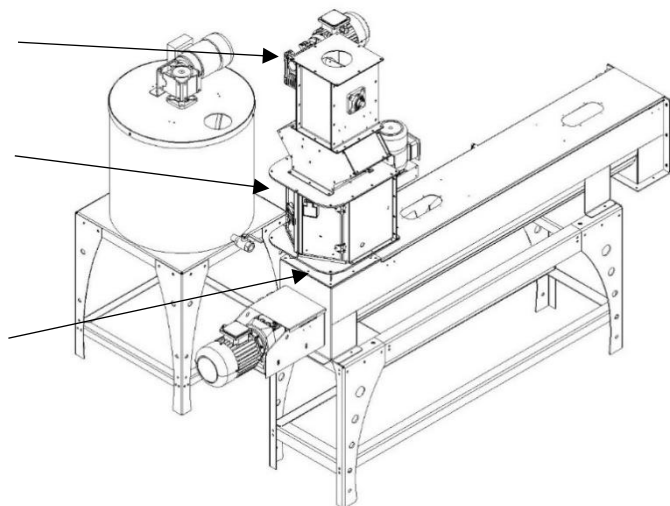

Technical data					
Model	CST 10	CST 20	CST 30	CST 40	CST 50
Capacity in tph Wheat	1.0 -2.50	2.50 - 5.0	5.0- 10.0	10.0 - 15.0	20.0 - 30.0
Total power requirement					
(with one liquid dosing pump)	2.57 kW	2.95 kW	2.95 kW	3.93 kW	4.63 kW
Power supply	3/N/PE 400 V, 50 Hz				
Aspiration	250 m <sup>3</sup> /h	300 m <sup>3</sup> /h	400 m <sup>3</sup> /h	500 m <sup>3</sup> /h	810 m <sup>3</sup> /h
Dimensions					
Length	1 700 mm	2 520 mm	2 650 mm	2 650 mm	4 215 mm
Width	800 mm	470 mm	470 mm	470 mm	590 mm
Height	1,500 mm	1630 mm	2 075 mm	2 250 mm	2 800 mm
Total weight of the treater					
Net	210 kg	250 kg	290 kg	385 kg	600 kg

Technical data can vary for the above options due to continued development or a different machine composition.

SINCE  
2080