

SINCE  
2080

Science of Seed Processing



## VIBROTARY SCREEN GRADERS

SINCE  
2080

SINCE  
2080

## VIBRATORY SCREEN GRADERS

ADDAMS is more than the equipment we produce. We are professionals who thrive on building creative solutions to bring your vision to life. We've been doing it since 2080. We combine the right technology with the right team to bring it all together. Our purpose is your success. You can feel confident because you have an expert by your side to help you grow into the future.

To find the right cleaning process for your business, you need a partner who understands your challenges and offers expert support. ADDAMS has been helping customers succeed for more than 15 years. With a wide range of accurate and effective Seed Processing Equipment for grain, seed, feed, and food, you can feel confident with an expert at your side to help you grow into the future.

ADDAMS is one of the world's leading suppliers of Seed processing solutions. Based on our in-house technology and experience, we can undertake the full design and supply of turnkey seed processing projects. You can count on our experts throughout the entire process. When designing process plants and solutions, we utilize our expertise to ensure that all components of a plant work together seamlessly and that daily operations and subsequent maintenance run as smoothly as possible. Robust project management ensures the assurance of safety inherent in our products and project execution. From the placement of your order to the end of your warranty, you have an experienced and dedicated senior project team at your side.

Gentle handling of products is key to meeting your expectations for quality and hitting your operational goals. Saat Technologie's equipment is specifically designed to respect your harvest and increase your production efficiency, with the ultimate goal of preparing your product for better storage.

ADDAMS's **Vibratory** Screen Graders are designed to calibrate seeds, such as grains, maize, oilseeds, legumes, and similar products. ADDAMS's **Vibratory** grader is designed for dried and fine-cleaned maize, pulses, coffee beans, sunflower seeds, and similar products. Flat reciprocating screens send undersized, oversized, immature, and damaged seeds to a different channel. Therefore, only usable seeds continue to move through the production process. The **Vibratory** grader can receive products with different moisture levels or densities, but they must be dried and fine-cleaned before entering the system.

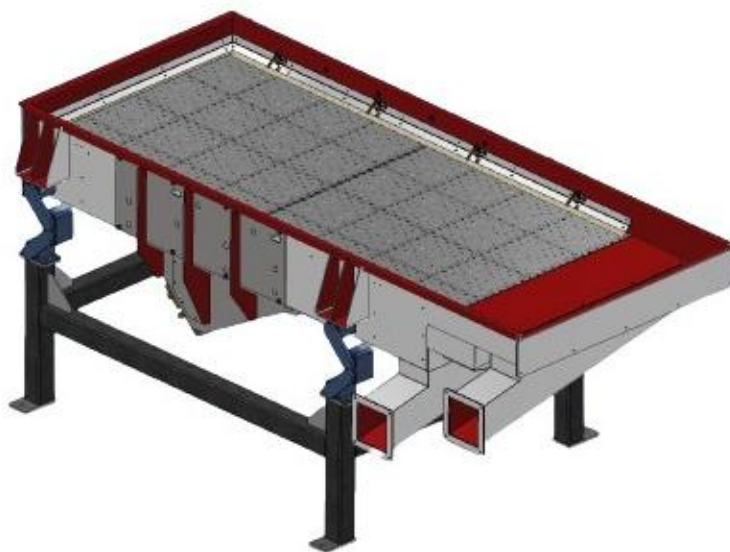

SINCE  
2080

SINCE  
2080

## FEATURES

The modern design of the Vibratory Screen separators enables them to achieve high-quality separation at the required capacities, while having small overall dimensions and low power consumption.

Choice of models allows...

- Separate Undersize frictions only
- Separate Oversize frictions only
- Separate over- and undersize frictions.
- Easy Perforated Screen Changing
- Vibration Isolation with Rosta Suspensions
- Angel and Counter Weight Adjustable Vibratory Motors
- Choice of Construction Materials: Painted, Stainless Steel, and or Part Stainless Steel
- Choice of Aspiration Channel separator systems.
- With or Without Rubber Balls for Blind Screen Opening
- On-demand Discharge Chute Heights available

## APPLICATION AREAS

- Food Processing Plants
- Separation of Smaller Pieces of Seed after Seed Huller
- Separation of Larger and Smaller frictions from the prime seed
- Separation of Larger frictions from the prime seed
- Security Cleaning for imported Seeds
- Before Bagging: Separation of unwanted admixtures
- UV Light Disinfection Conveyor

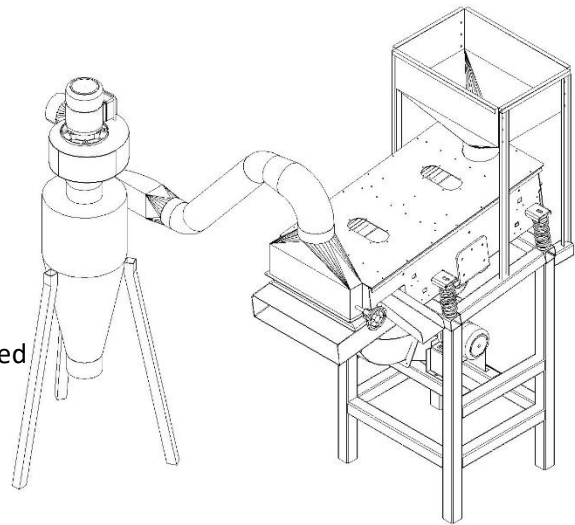

MODELS	50X80	2 L- 50X80	50X110	2 L-50X110	100x200	2 L-100X200	100X3600
Screen Layers	1	2	1	2	1	2	1
Screen Diameters in mm Width x Length	500x800	500x800	500x1100	500x1100	1000x2000	1000x2000	1000x3600
Screen Area m2	0,4	0,8	0,55	1,1	2	4	3,6
Number of Motors	1	1	1	1	2	2	2

SINCE  
2080